

FREQUENCY and PERIOD
 Range .001 Hz to 1.3 GHz
 Resolution 11 digits in 1 second
 Error <100 ps/gatetime+timebase

PHASE
 Range +/-180 degrees
 Resolution (25ps x Freq x 360 + .001)
 Error <(1ns x Freq x 360 + .001)

TIME INTERVAL ARMING
 +TIME Stop is armed by Start
 +TIME_EXT Ext arms Start
 +TIME_EXT_HOFF Leading EXT edge arms Start, trailing EXT edge arms Stop
 +TIME Armed by Start/Stop pair
 +TIME_CMPL Armed by Stop/Start pair
 +TIME_EXT Armed by EXT input edge

TIME, WIDTH, RISE/FALL TIMES
 Range +/-1000 s
 LSD 4 ps (single-shot)
 Resolution 25 ps, rms (typ)
 Error (Abs) < 1 ns+timebase
 (Rel) <100 ps+timebase

SAMPLE SIZE
 Select 1 to 10⁶ measurements for statistical analysis (Mean,Min,Max,Jitter). Push Start to begin one group of measurements or push and hold for continuous measurements. Reset will restart a group of measurements.

EXT INPUT
 This input is used for external arming and gating, and as a trigger for delayed arming or scanning gates. Thresholds from +5.00 V with 10 mV resolution. Positive or negative logic, 1 MOhm or 50 Ohm input. Inputs may range from 3 ns to 1000 s.

REF OUT
 A 1 KHz squarewave with ECL or TTL levels. Can drive 50 Ohm loads with a 2 ns transition time. Synchronous with the timebase for very low jitter and a 50% duty cycle. This output may be used to trigger devices under test.

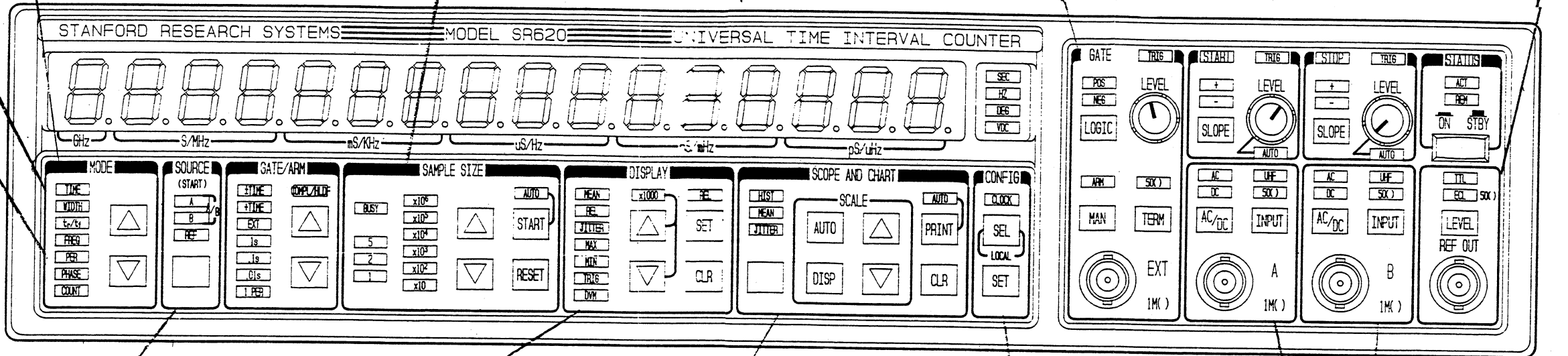

SOURCE (START) SELECTION
 A A is the source
 B B is the source
 A&B Ratio of A/B
 REF REF OUT is source

DISPLAY
 MEAN Mean value
 REL Offset for RELative values
 JITTER Std dev or Allan variance
 MAX Largest value in a sample
 MIN Smallest value in a sample
 TRIG Levels for EXT, A and B
 DVM Volts at rear panel DVM's
 x1000 Femtoseconds/nanoHertz
 SET/CLR Set or clear the REL offset

SCOPE and CHART
 HIST Display histogram of values
 MEAN Display strip chart of means
 JITTER Display strip chart of Jitters
 SCALE AUTO to scale displays
 DISP to set display scales
 CURSOR to read values
 PRINT Print/plot scope display
 CLR Clear scope display

CONFIG Four menus for configuration
 The "Control" menu is used to set GPIB address, RS232 baud rate, and view RS232/GPIB commands. A "CAL" menu allows automatic calibration and adjustment of the internal timebase. Other menus for hard copy support and scanning.

A & B INPUTS
 Similar to high speed scope inputs, they may be ac/dc coupled, 1 MOhm or 50 Ohms, and levels may be set and displayed to 10 mV resolution. AUTOLEVEL circuits can select the best level. The slope may be specified for triggering, and prescalers are available on both inputs for frequencies to 1.3 GHz.

DVM INPUTS
 May be read by computer via RS232 or GPIB or viewed on front panel. One megaohm isolated differential inputs with either +2 or +20 volts full-scale.

STRIP CHART / DAC OUTPUTS
 Analog voltages proportional to the mean value and jitter to drive strip chart recorders. The scale factors (linear or log) may be set on the front panel. The outputs may also serve as general purpose DAC outputs which may be set or scanned over a +/-10 Vdc range with 5 mV resolution. A typical application would be the characterization of a VCO's linearity.

TIMEBASE I/O
 Outputs a 10 MHz sinewave from the timebase. The timebase may be calibrated via the front panel calibration menu. An external timebase of 5 or 10 MHz may be applied.

GPIB(IEEE-488)/RS232
 GPIB and RS232 ports for computer control and data acquisition. All functions may be controlled via the interfaces (even input levels), and all results may be read back to the computer (ASCII and binary-dump).

SCOPE OUTPUTS
 Drive any XY scope for displays of histograms, and strip charts of mean values and jitters. 25 pixels per division on an 8x10 division scope screen. The displays include text for scale factors and cursor read-outs of individual values. The scope refresh is synchronized to the line frequency for a sharp and stable display.

PRINTER PORT
 Centronics printer port for hard copy of scope displays. Any Epson compatible graphics printer may be used. May also be used as an eight bit digital I/O port.

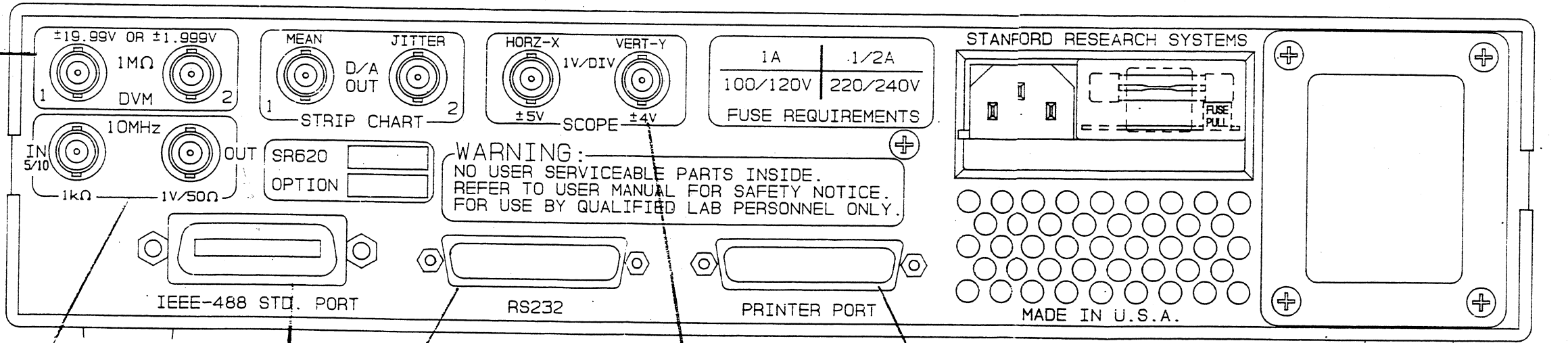

SR620 Universal Time Interval Counter Visual Index

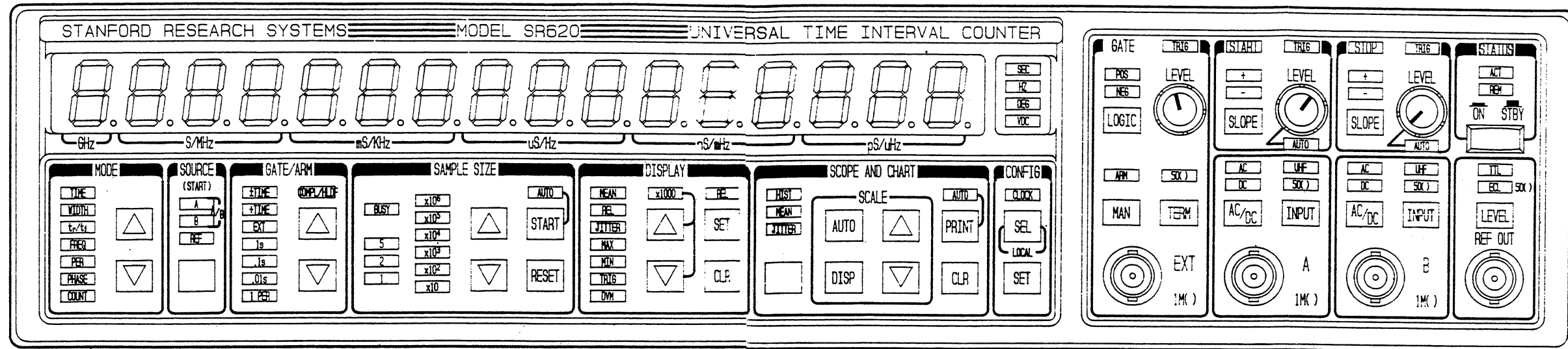

MODE
3
S9
MODE

FRONT PANEL

Operation
Circuit Schematic
Control Commands

| | SOURCE | GATE/ARM | SAMPLE SIZE | DISPLAY & REL | SCOPE & CHART | PRINT & PLOT | CONFIG | EXT | A & B INPUTS | REF OUT |
|--|---------------|--------------------------------|-------------------------|---------------------|----------------------------------|---------------------------------------|-------------------------|-------------------------------------|----------------------------------|---------------|
| | 3 | 11 - 16 | 3 | 5 | 5-8 | 6,18 | 17 - 22 | 9,10,19 | 9,10,19 | 10 |
| | 86,S9 SRCE | 87,S6,S9,S10 ARMM,COMP,GATE | SIZE,STRT, STOP,AUTM | 91,S16 DISP,DREL | 82,S3 GENA,DGPH, AUTS,GCLR | 81,S2 PLOT,PDEV, PLAD,PLPT,PCLR | SCAN,VOUT, DBEG,DSTP | 86,S8,S9 LEVL,MTRG, ARMM,TERM | 86,S8 LEVL,TERM, TCPL,TSLP | 84,S6 RLVL |

REAR PANEL

Operation
Circuit Schematic
Control Commands

| TIMEBASE | DVM's | DAC's | GPIB | RS232 | POWER SUPPLY |
|----------------------------|----------------------------------|---|----------------|----------------|------------------|
| 10,18 85,S7 CLK,CLKF | 10,18 83,89,S12 VOLT?,RNGE | 7,19 - 22 83,90,S12 VBEG,VSTP, VOUT,SCEN | 17,29 81,S2 | 17,29 82,S2 | iv 90,S13,S14 |

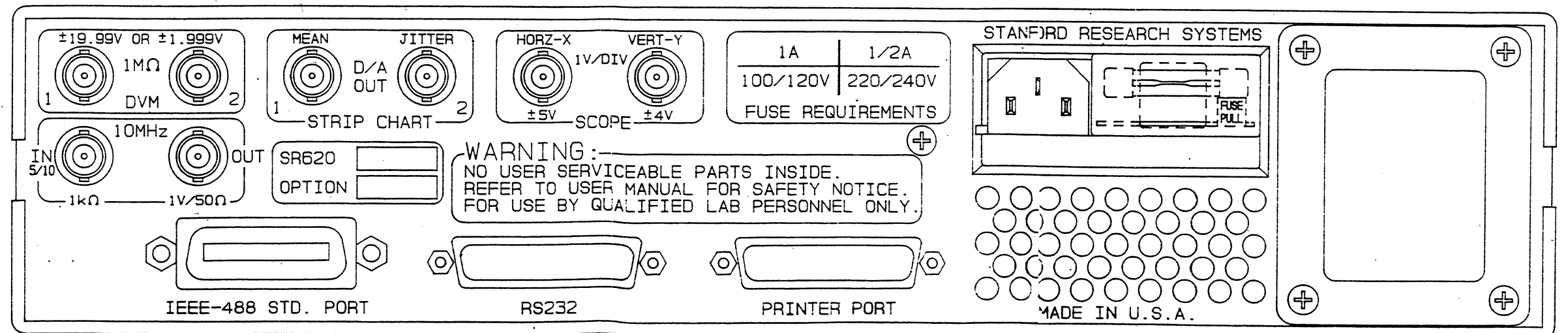

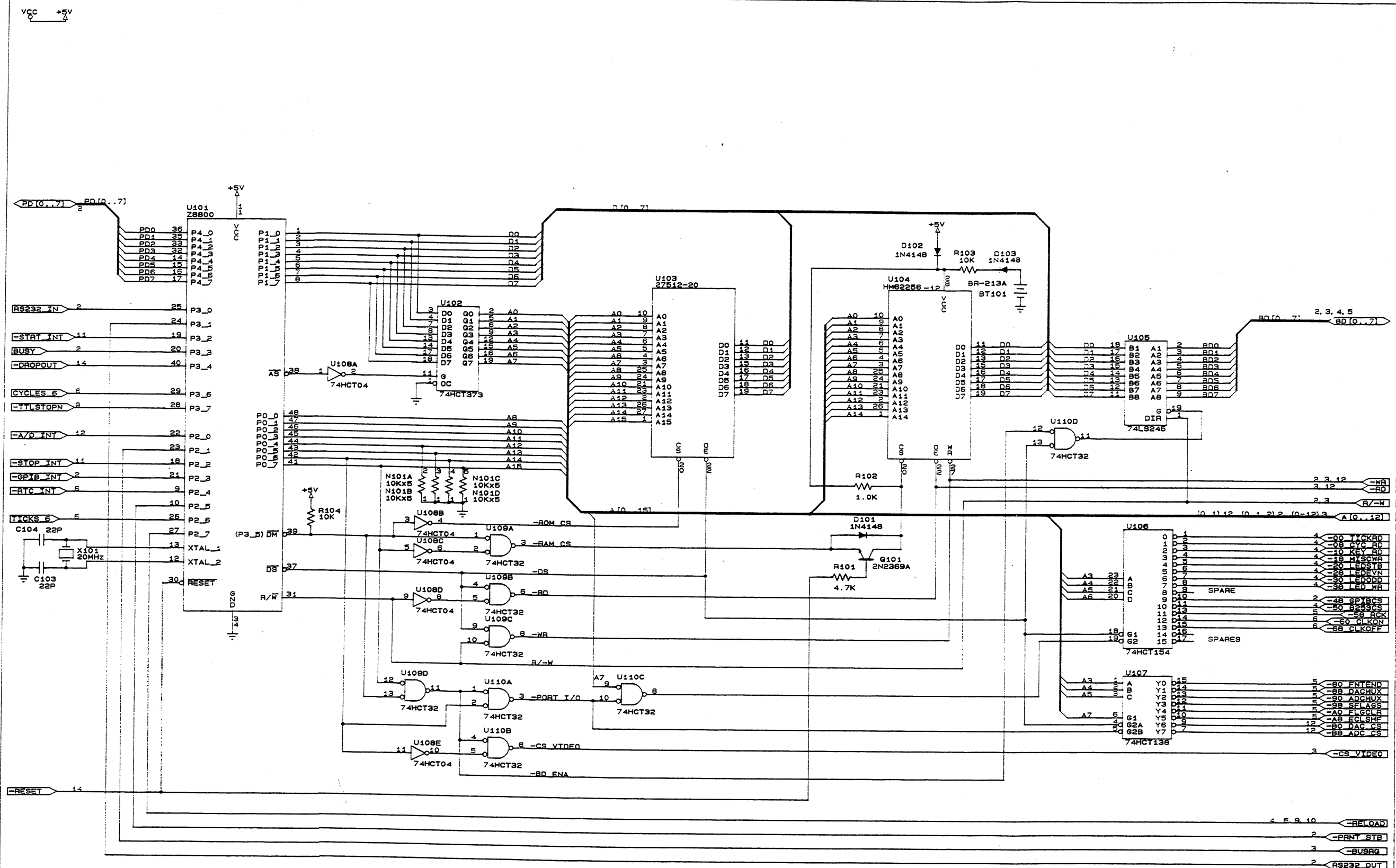

U108F ON SHEET 2

| | | |
|-----------------------------|-----------------|---------------|
| STANFORD RESEARCH SYSTEMS | | |
| Title MICROPROCESSOR SYSTEM | | |
| Size Document Number | SR620-1 | REV |
| C | | D |
| Date: | January 9, 1989 | Sheet 1 of 16 |

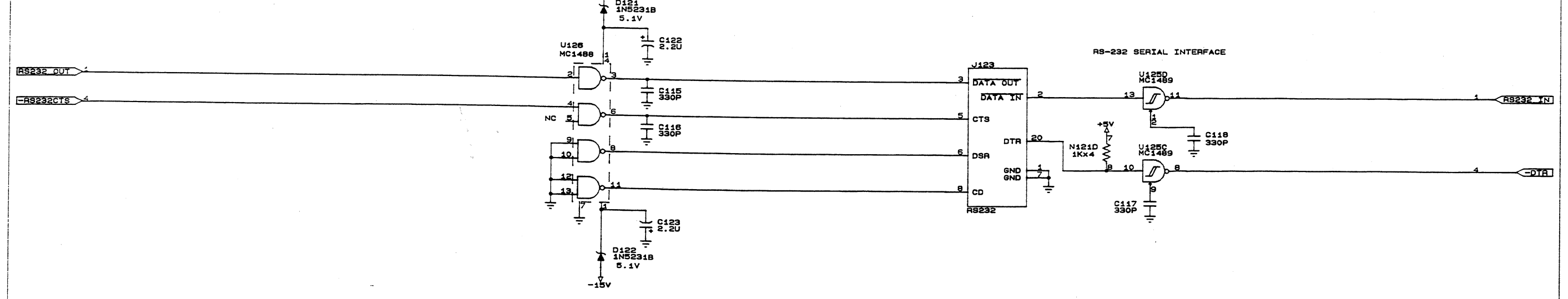
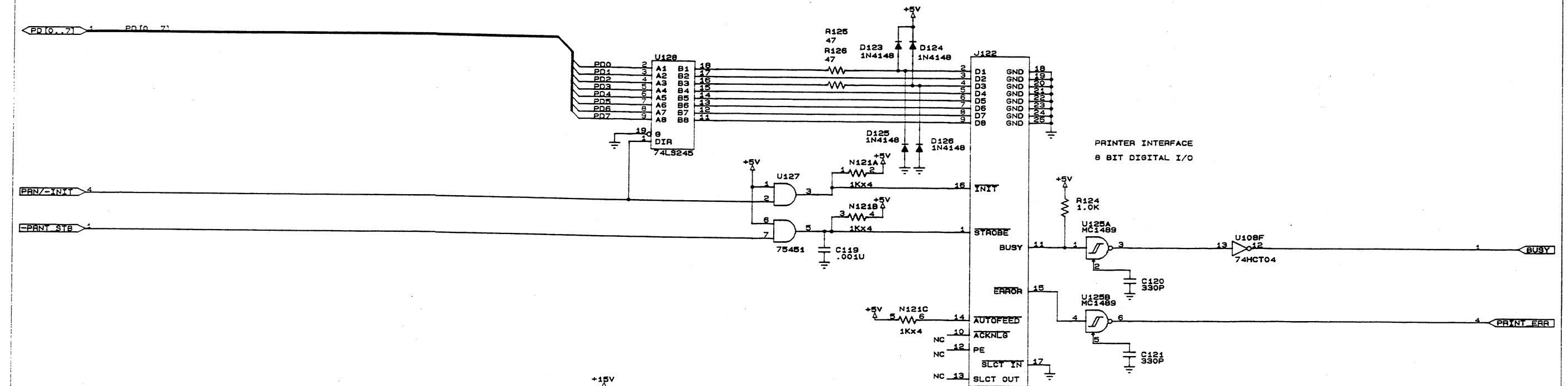
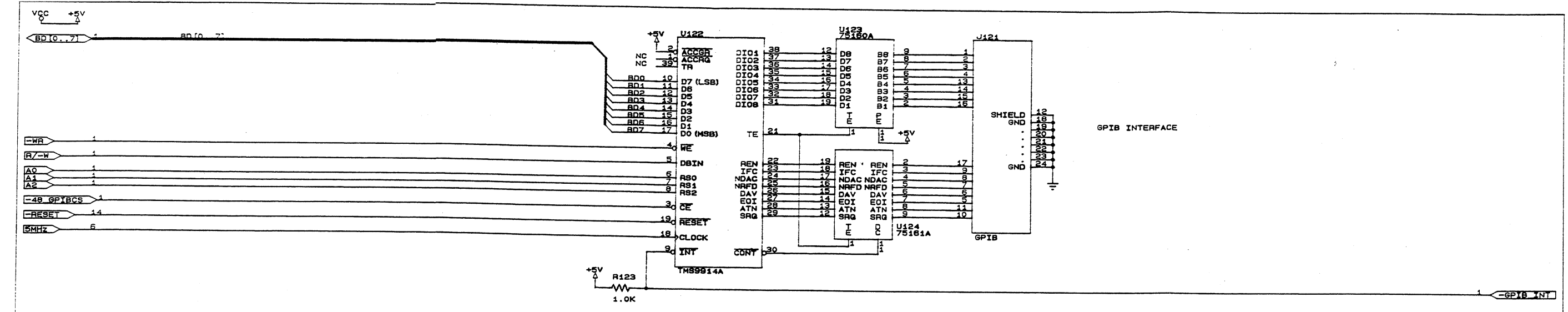

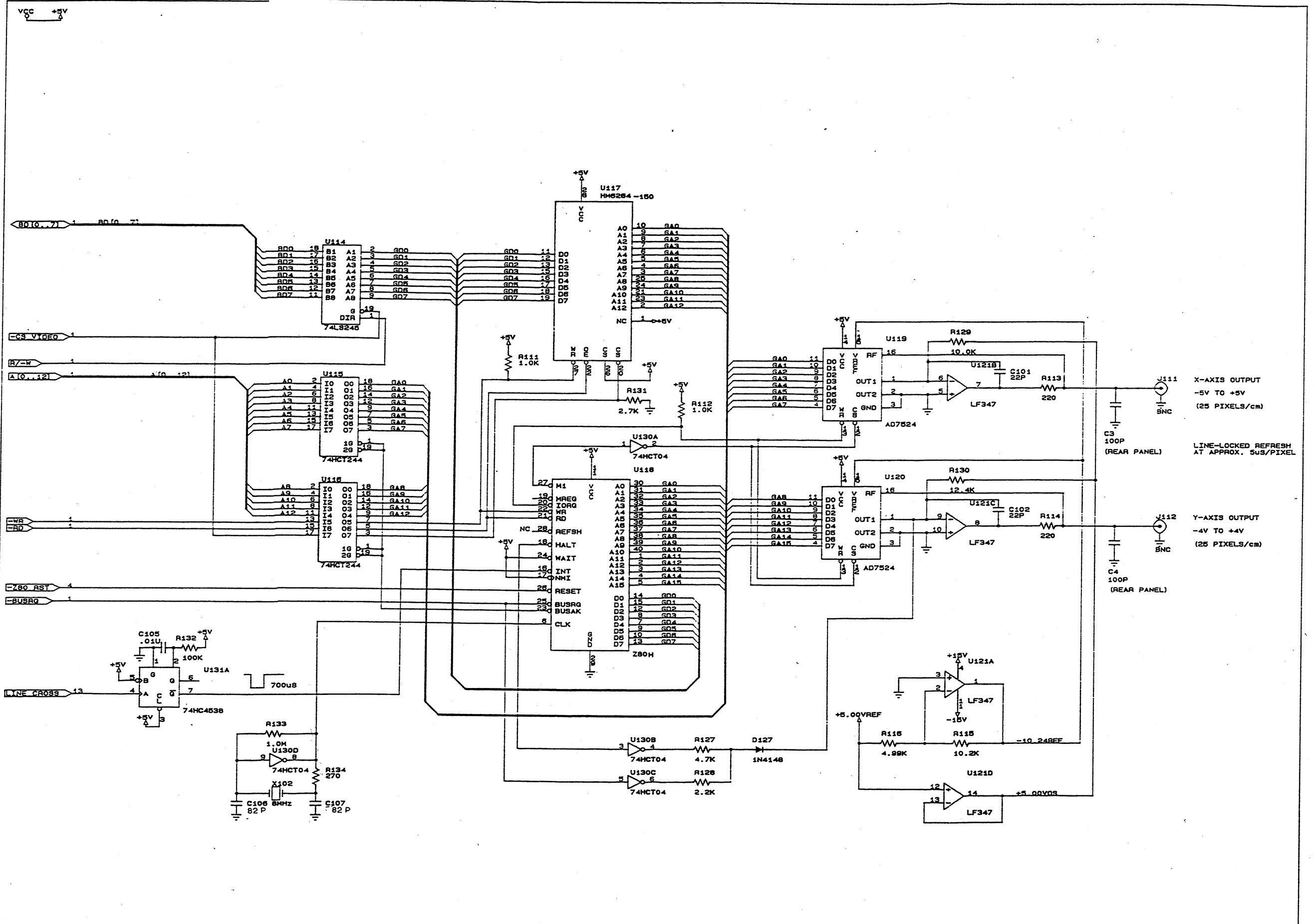

U131B ON SHEET 4
 U130E ON SHEET 5
 U130F ON SHEET 12

| | |
|--------------------------------------|-----|
| STANFORD RESEARCH SYSTEMS | |
| Title VIDEO GRAPHICS CONTROLLER | |
| Size Document Number | REV |
| C SR620-3 | E |
| Date: October 30, 1988 Sheet 3 of 16 | |

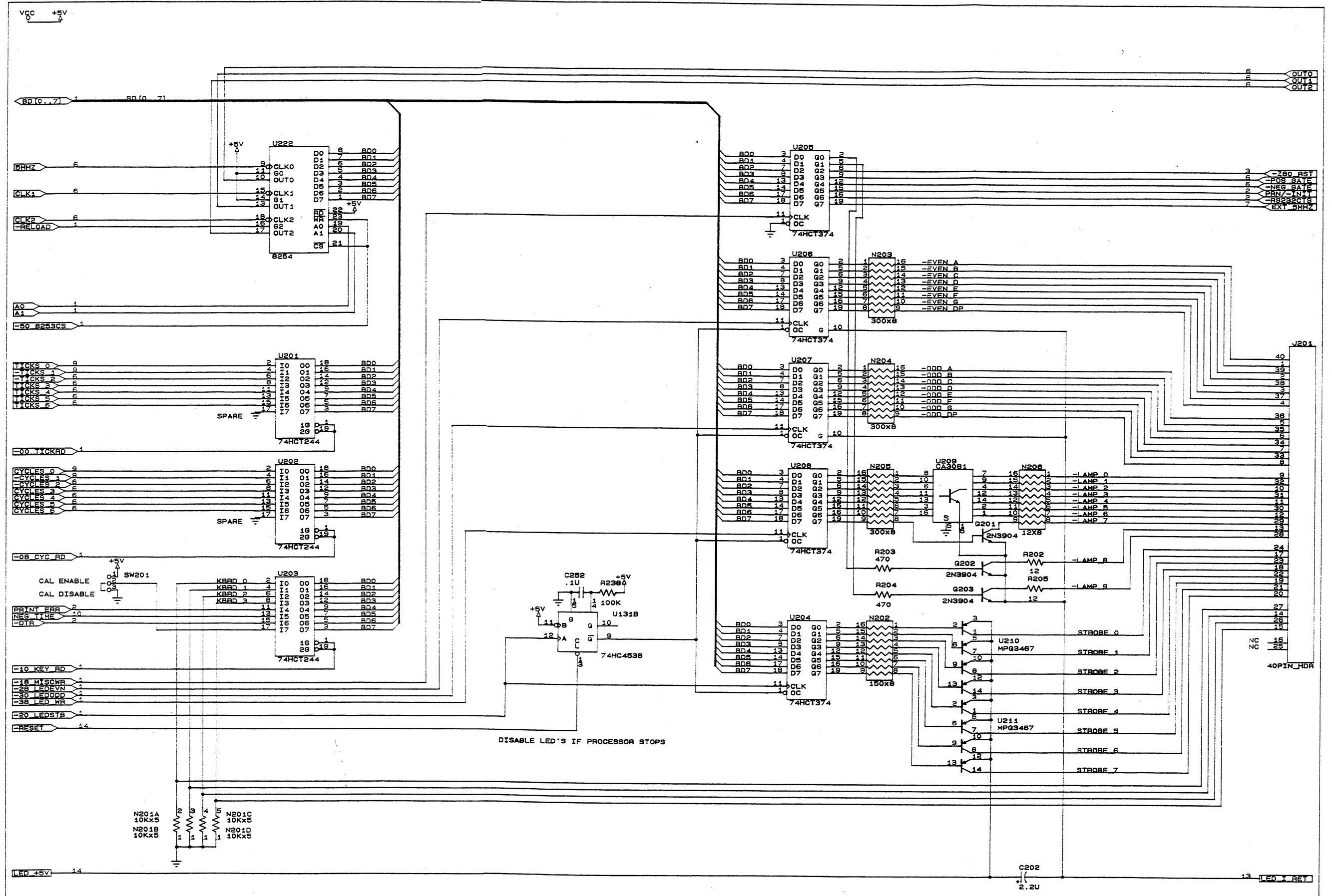

DISABLE LED'S IF PROCESSOR STOPS

| | | |
|---------------------------|---------------------------|---------------|
| STANFORD RESEARCH SYSTEMS | | |
| Title | I/O PORTS AND LED DRIVERS | |
| Size Document Number | SR620-4 | REV |
| C | | D |
| Date: | October 26, 1988 | Sheet 4 of 16 |

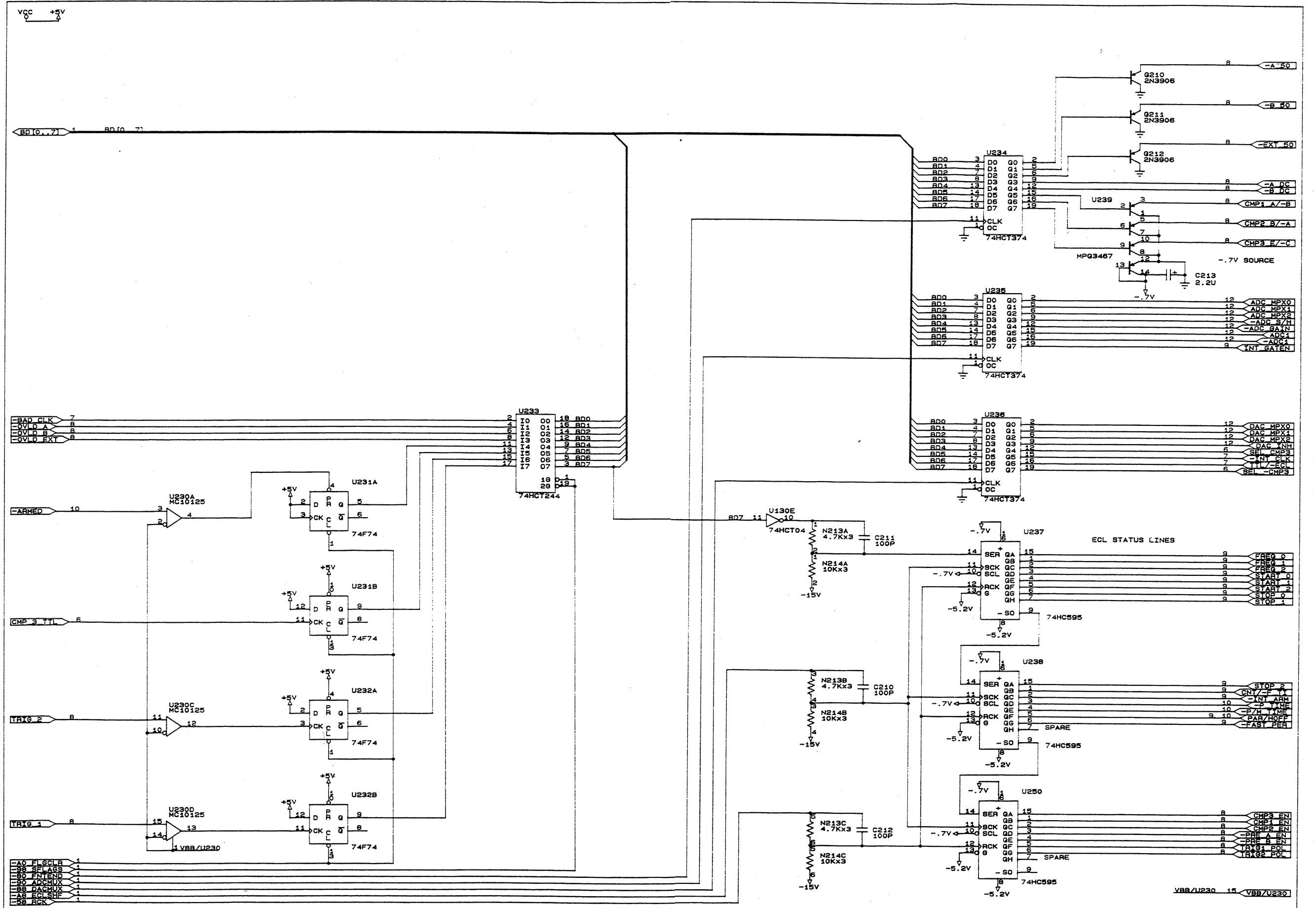

STANFORD RESEARCH SYSTEMS

Title: ANALOG AND ECL I/O

Size Document Number: SR620-5 REV D

Date: October 26, 1988 Sheet 5 of 16

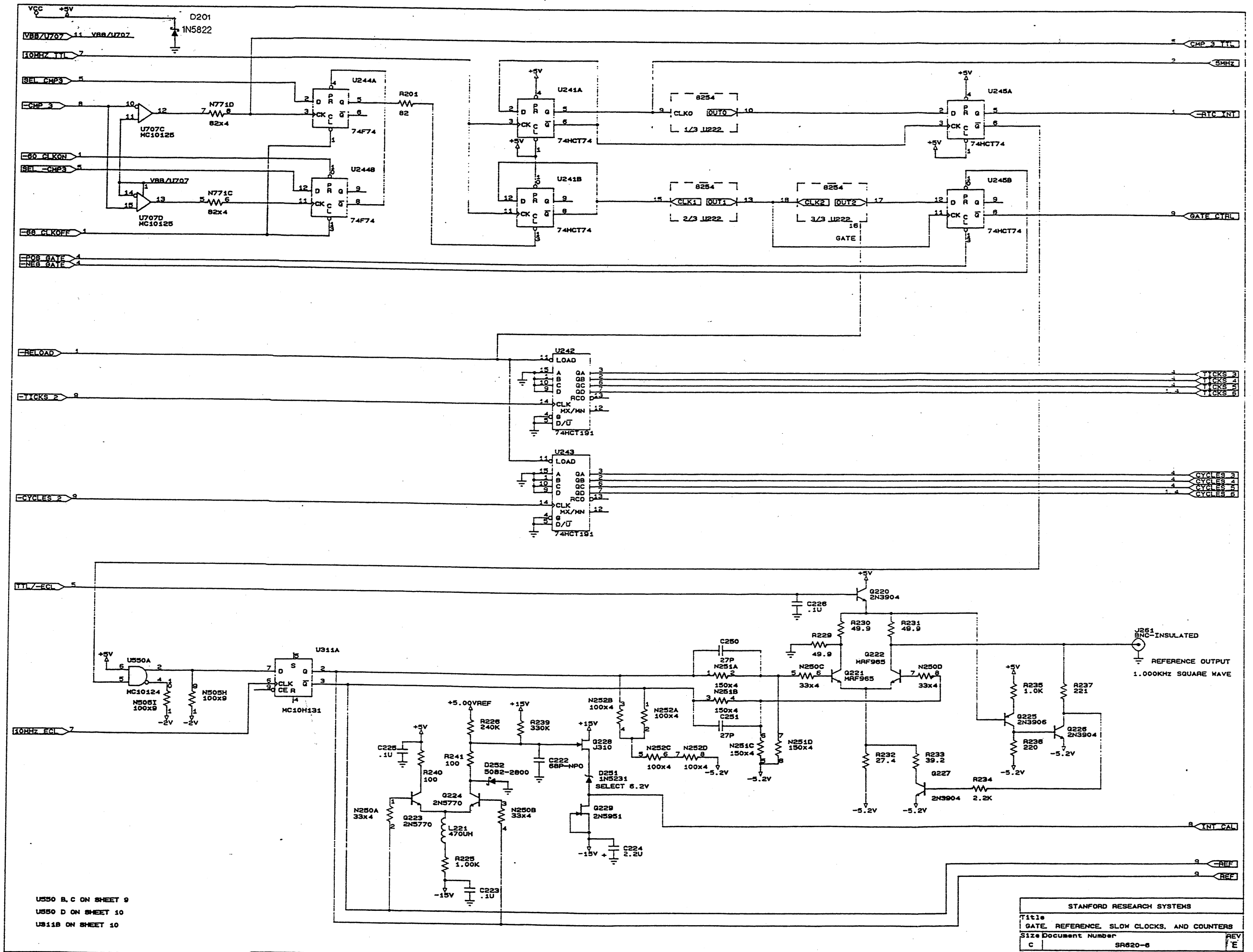

U550 B, C ON SHEET 9
 U550 D ON SHEET 10
 U811B ON SHEET 10

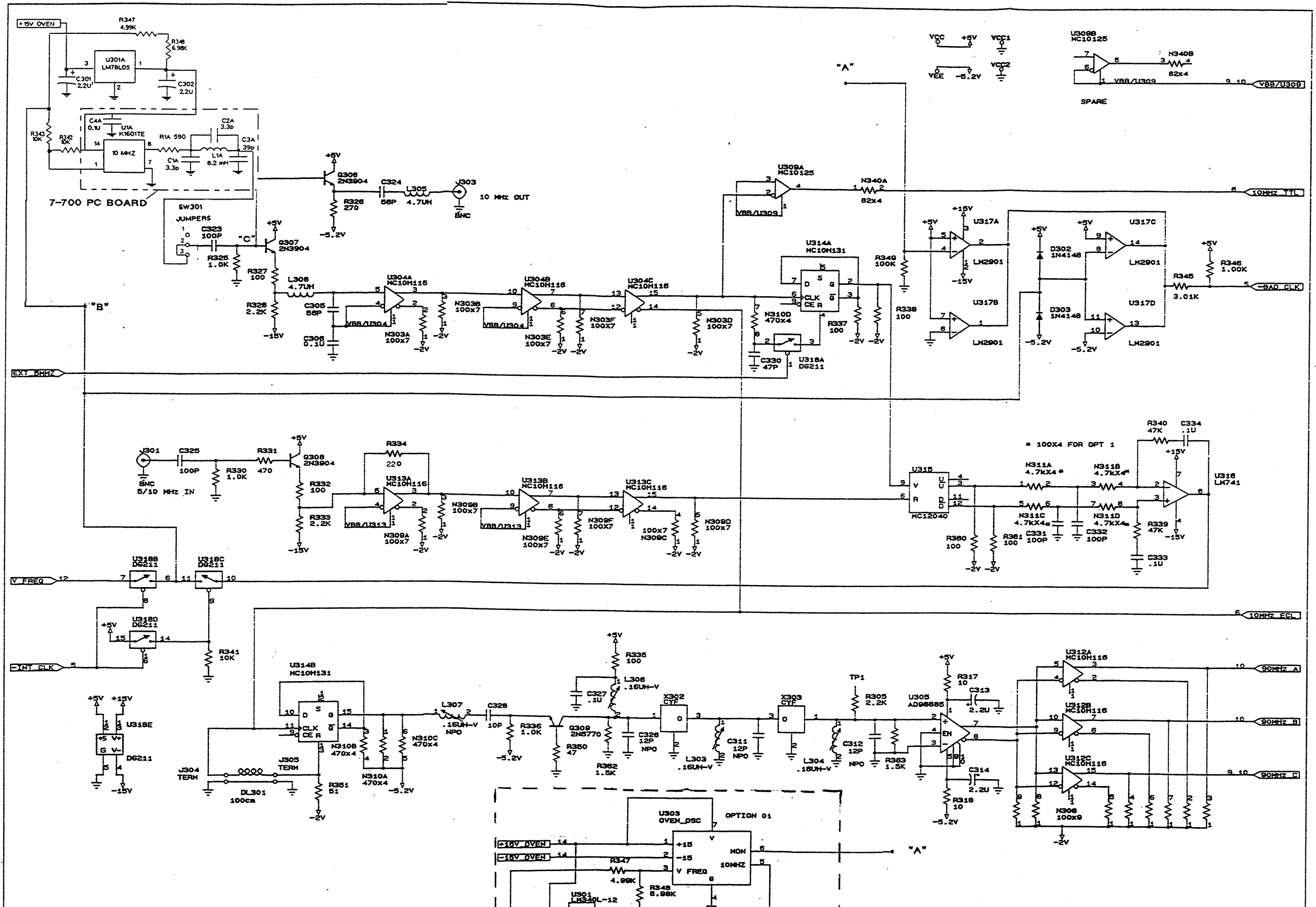

NOTE:
 U309C ON SHEET 8, U309D ON SHEET 10
 "A", "B", "C" ARE CONNECTIONS POINTS FOR OPTION 1.

| | | |
|--|-----------------|---------------|
| 6-13-95 | 1209 | E |
| 2-16-95 | 1180 | E |
| DATE | ECO | REVISION |
| STANFORD RESEARCH SYSTEMS | | |
| Title FAST CLOCKS AND REFERENCE OUTPUT | | |
| Size Document Number | SR620-7 | REV E |
| Date | January 9, 1999 | Sheet 7 of 16 |

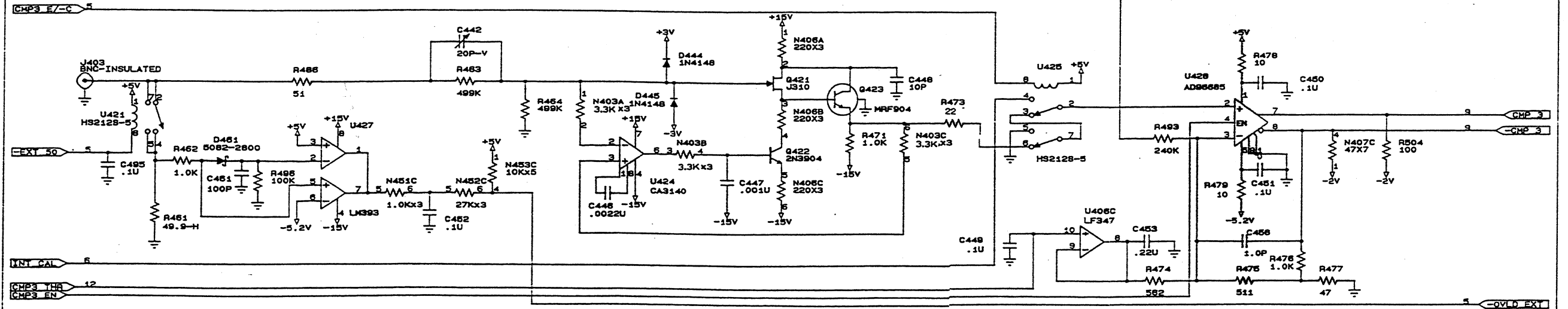
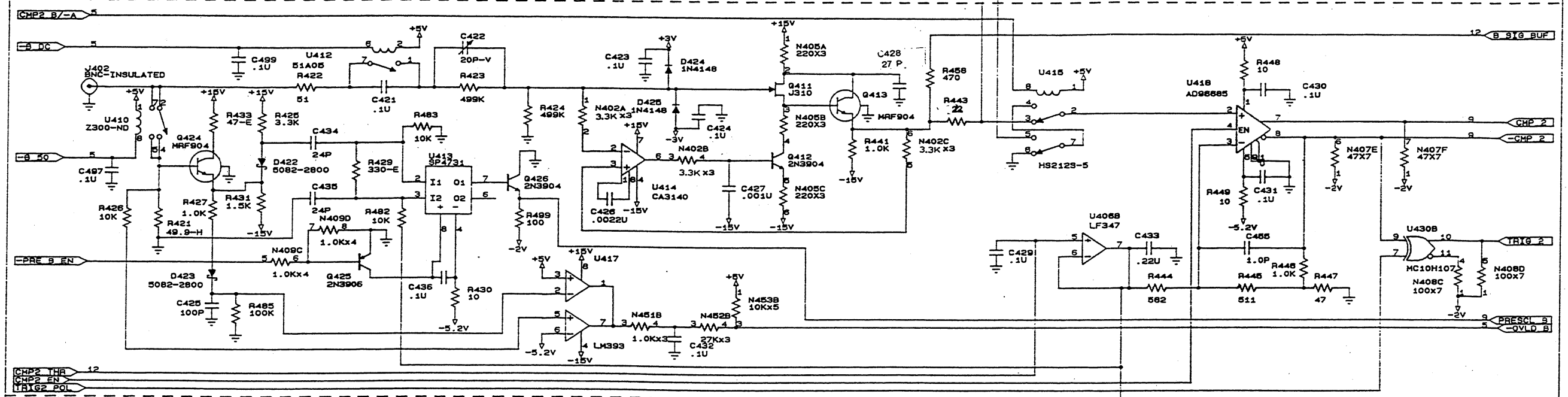
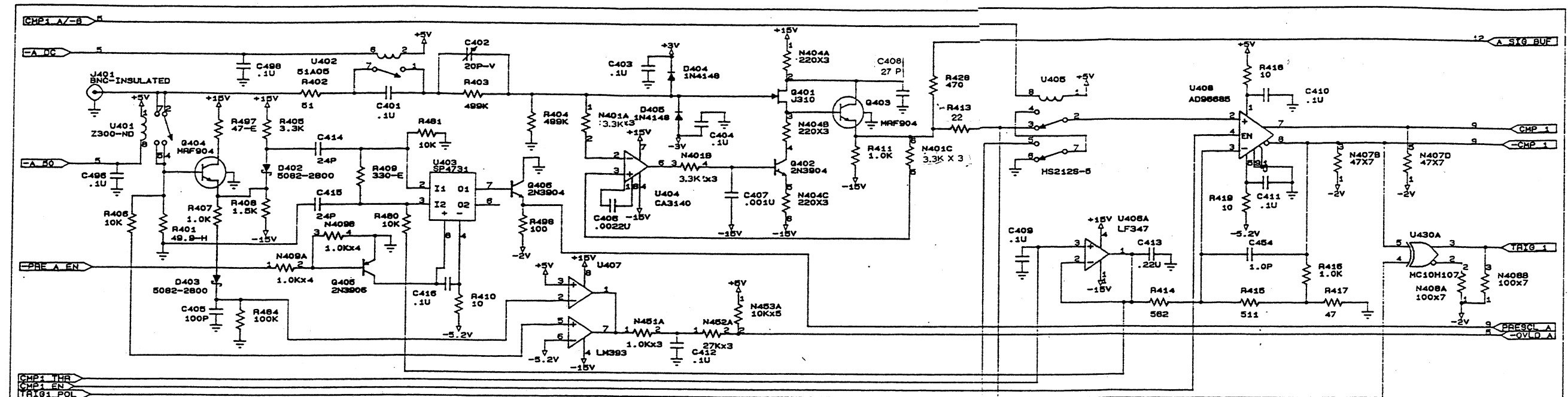

U406D SPARE
U430C ON SHEET 9

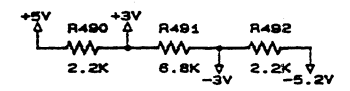

| | |
|---------------------------|-------------------------------|
| STANFORD RESEARCH SYSTEMS | |
| Title | INPUT COMPARATORS |
| Size Document Number | SR820-8 |
| Date | January 9, 1989 Sheet 8 of 16 |

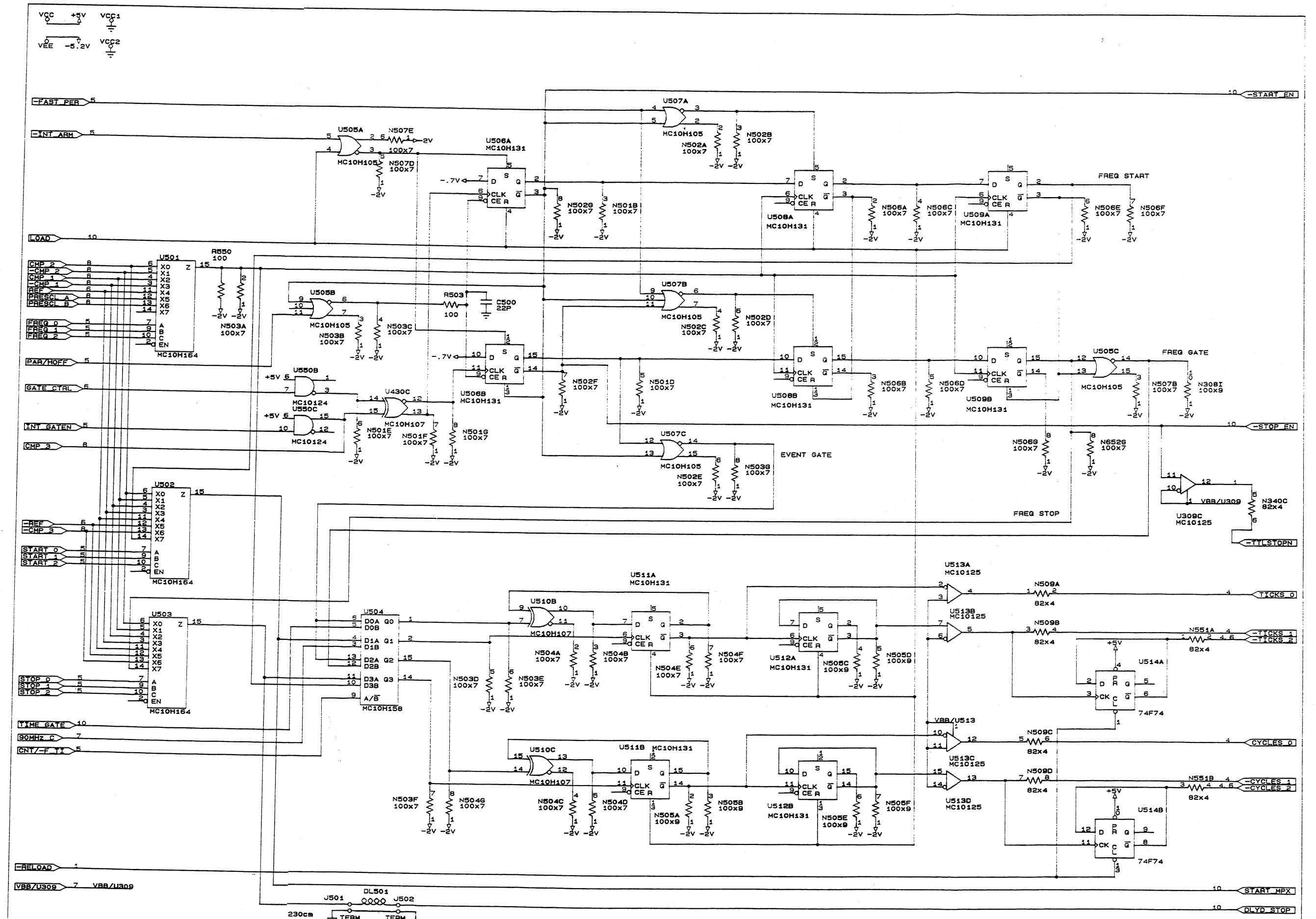

U501A ON SHEET 10
 U310 A ON SHEET 6
 U310 D ON SHEET 10

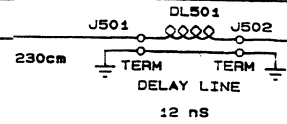

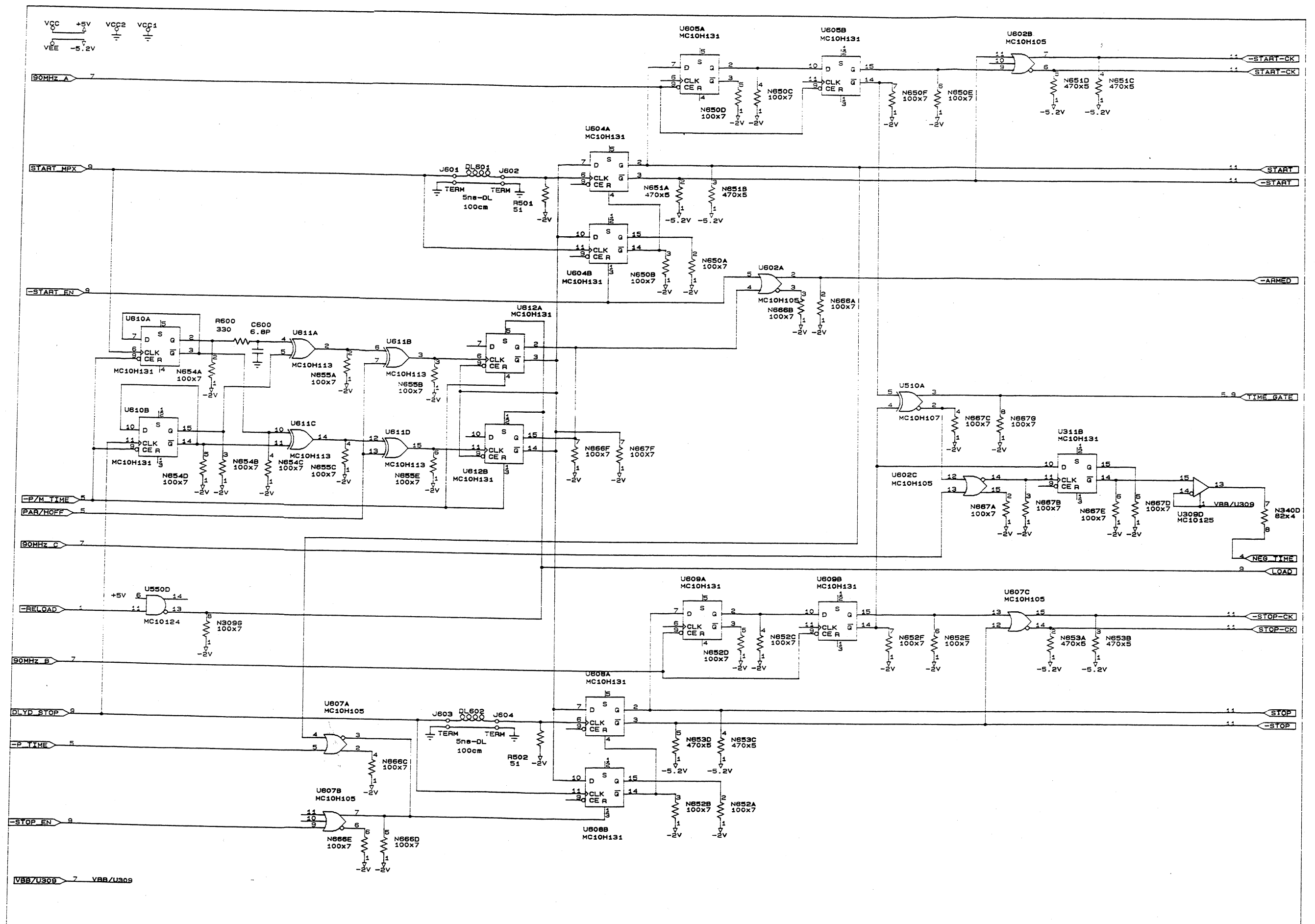

U311A ON SHEET 6

| | | |
|---------------------------|--------------------------|----------------|
| STANFORD RESEARCH SYSTEMS | | |
| Title | FAST TIME INTERVAL LOGIC | |
| Size Document Number | REV | |
| C | SR620-10 | D |
| Date: | October 26, 1988 | Sheet 10 of 15 |

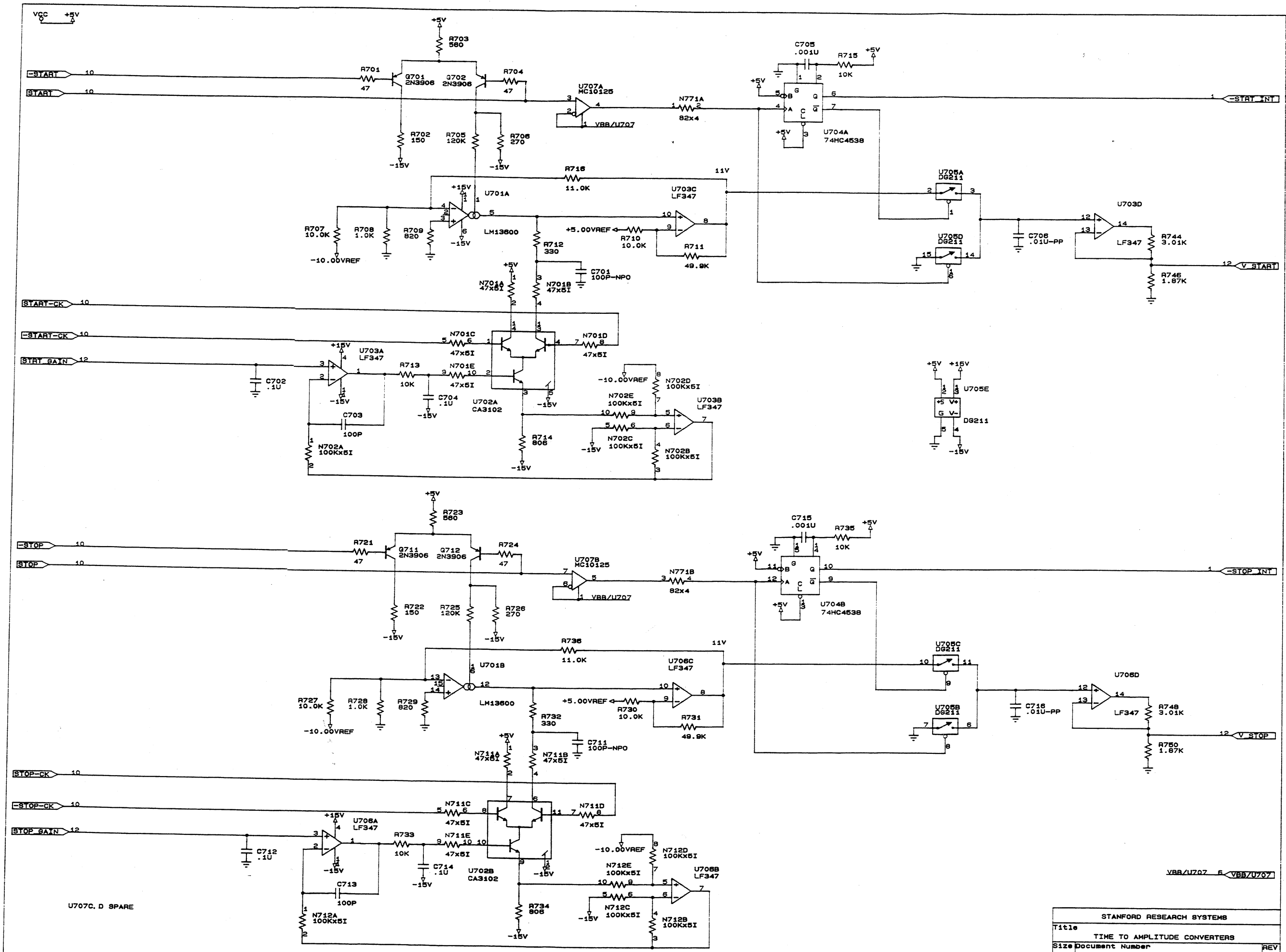

| | | |
|------------------------------|-----------------|----------------|
| STANFORD RESEARCH SYSTEMS | | |
| Title | | |
| TIME TO AMPLITUDE CONVERTERS | | |
| Size | Document Number | REV |
| C | SR820-11 | D |
| Date: | January 9, 1989 | Sheet 11 of 15 |

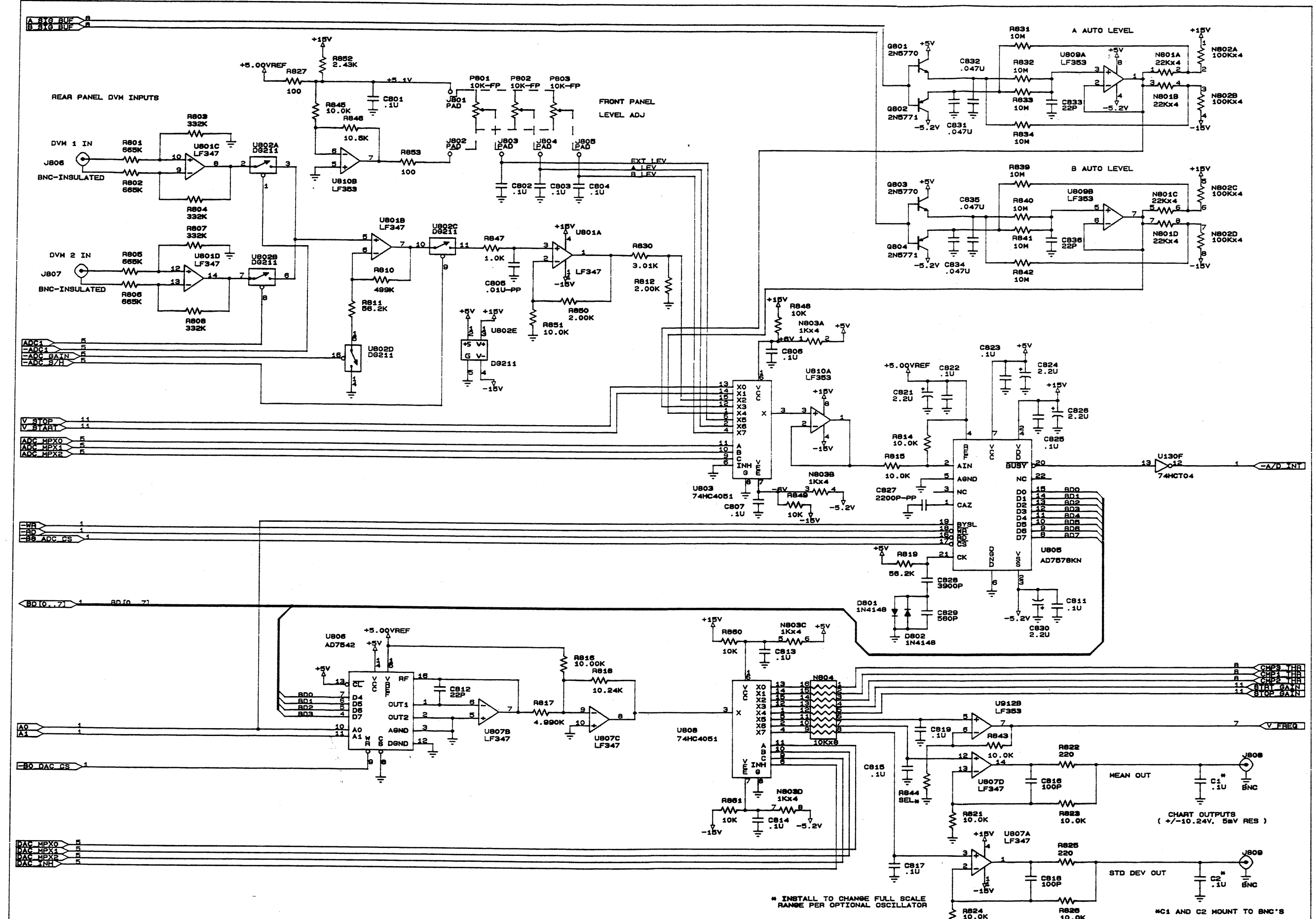

* INSTALL TO CHANGE FULL SCALE RANGE PER OPTIONAL OSCILLATOR

| | | |
|-----------------------------------|----------|----------|
| STANFORD RESEARCH SYSTEMS | | |
| Title A/D, D/A, AND THRESHOLDS | | |
| Size Document Number C | SRS20-12 | REV D |
| Date: January 9, 1989 | Sheet | 12 of 16 |

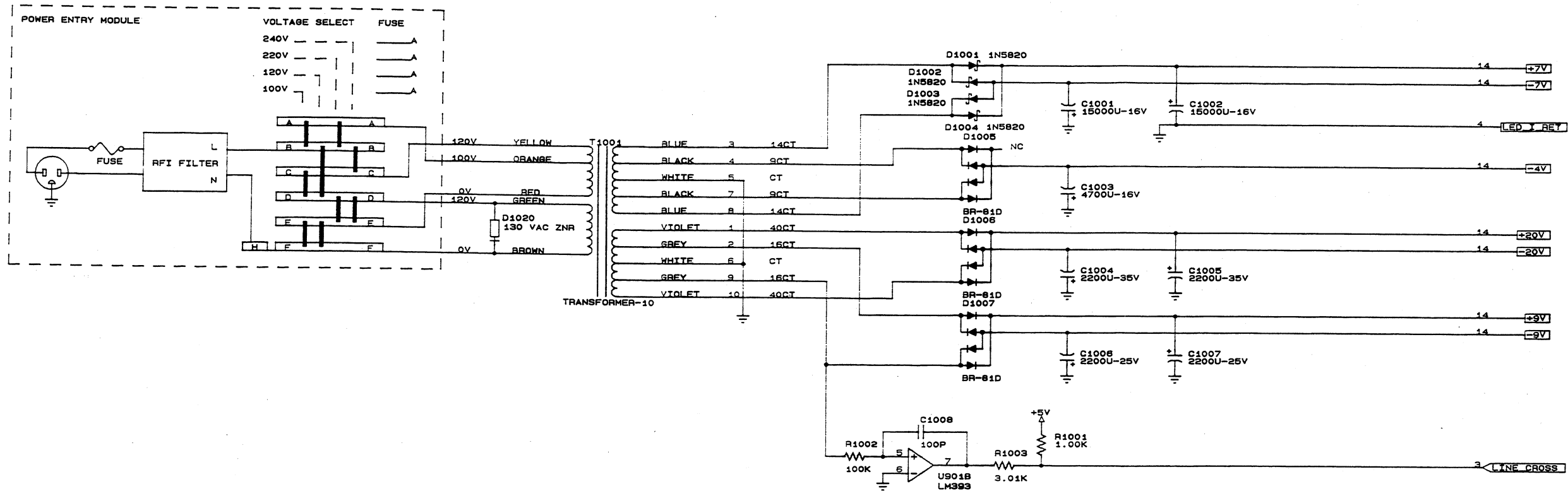

| | | |
|--|-----------------|-----|
| STANFORD RESEARCH SYSTEMS | | |
| Title UNREGULATED POWER SUPPLIES | | |
| Size | Document Number | REV |
| C | SR620-13 | D |
| Date: November 10, 1988 Sheet 13 of 16 | | |

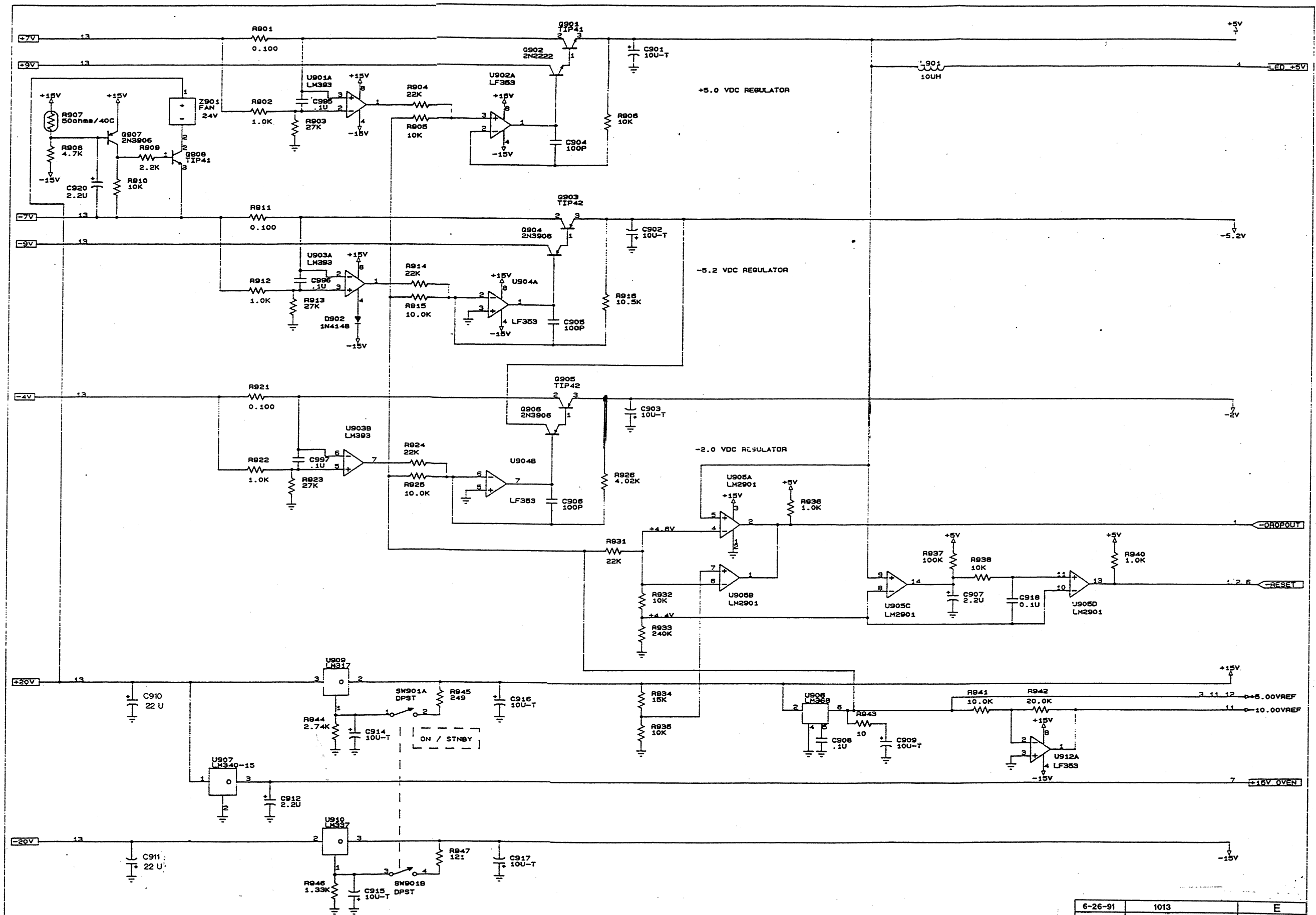

U902B SPARE
U912B ON SHEET 12

| | | |
|---------------------------------------|------|----------|
| 6-26-91 | 1013 | E |
| 2-16-95 | 1180 | E |
| DATE | ECO | REVISION |
| STANFORD RESEARCH SYSTEMS | | |
| Title POWER SUPPLY REGULATORS | | |
| Size Document Number C SR820-14 | | REV E |
| Date: October 27, 1988 Sheet 14 of 16 | | |

VCC2

VBB/U230 5 VBB/U230

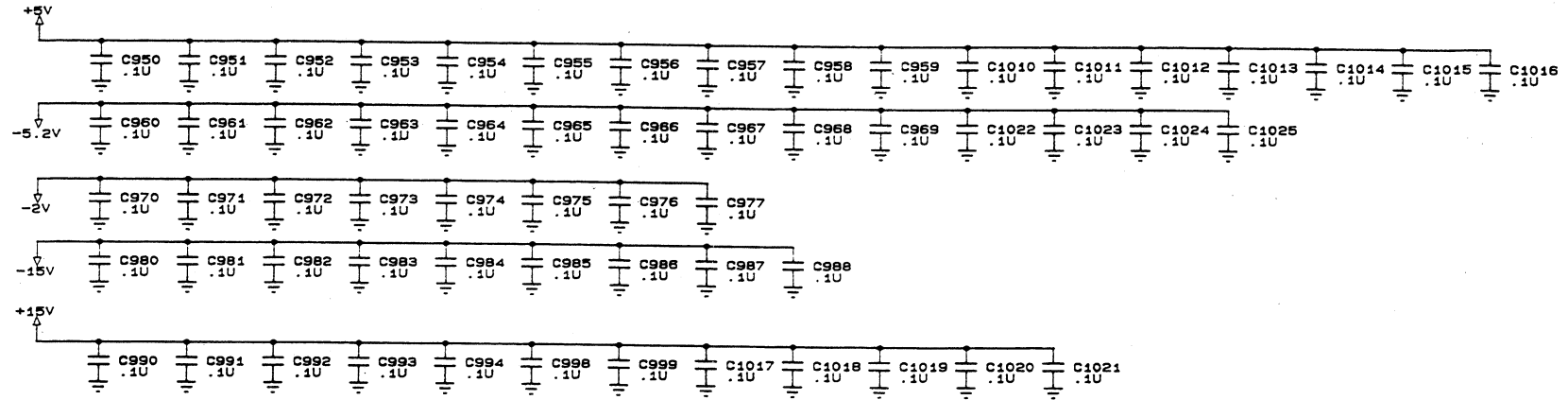
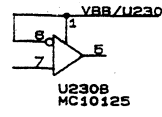
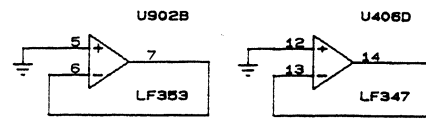

| | | |
|----------------------------------|------------------|----------------|
| STANFORD RESEARCH SYSTEMS | | |
| Title SPARES AND DECOUPLING CAPS | | |
| Size | Document Number | REV |
| C | SR620-15 | D |
| Date: | October 31, 1988 | Sheet 15 of 16 |

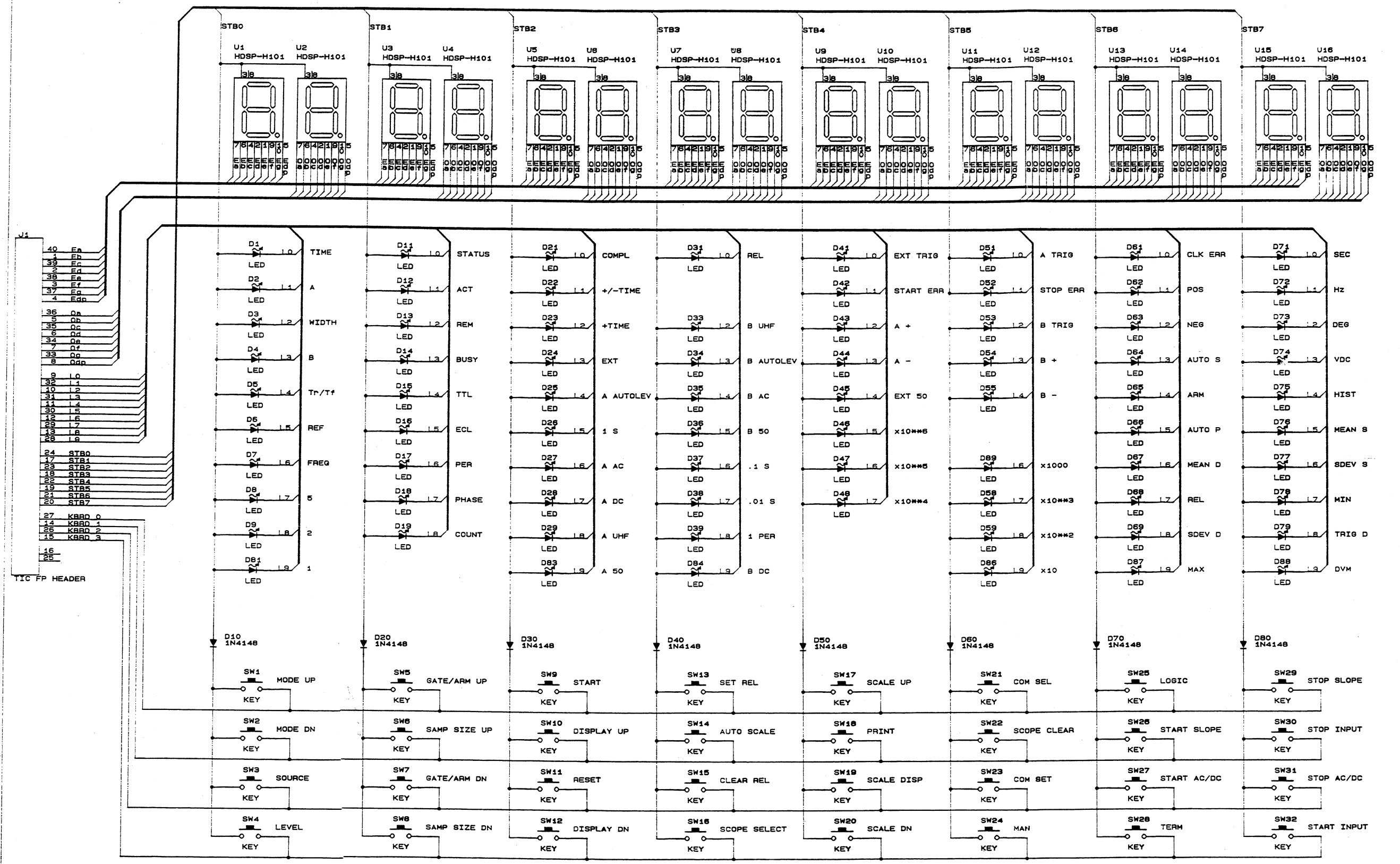

| STANFORD RESEARCH SYSTEMS | | |
|---------------------------|--------------------------|----------|
| Title | U.T.I.C. FRONT PANEL PCB | |
| Size Document Number | SR620-16 | REV C |
| Date: | July 22, 1988 Sheet | 16 of 16 |

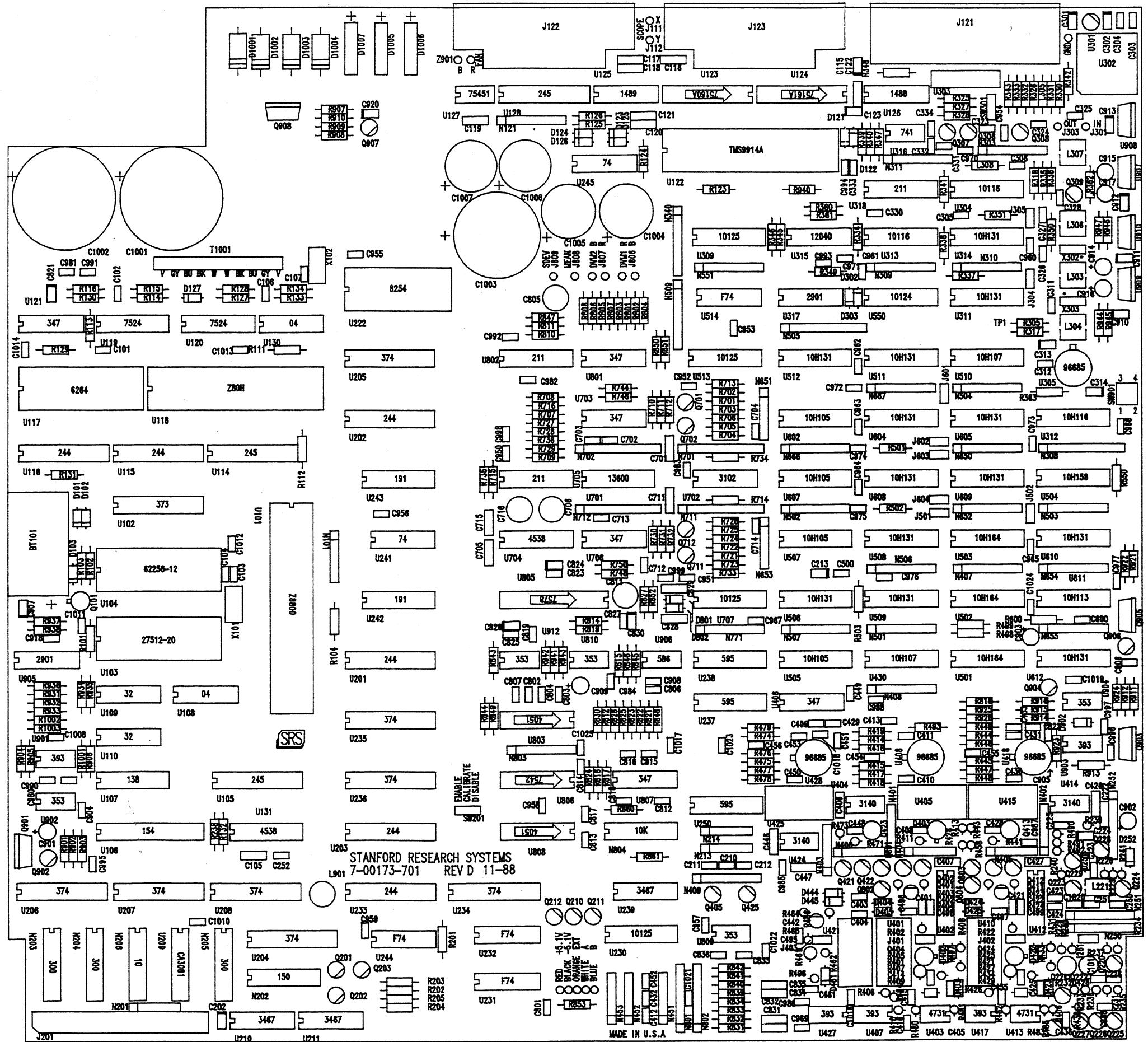

4801
4802
4803
4804
4805